



**Synertek
Systems**

**KTM-2 & KTM-2/80
REFERENCE MANUAL**

KTM-2 & KTM-2/80 REFERENCE MANUAL

Copyright © by Synertek Systems Corporation

All rights reserved. No part of this publication may be reproduced, stored in a retrieval system, or transmitted in any form or by any means, electronic, mechanical, photocopying, recording or otherwise, without the prior written consent of Synertek Systems Corporation.

SSC Pub MAN-A-260018-H

Sixth Printing: February, 1981

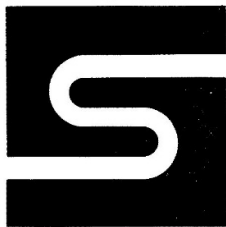

Synertek Systems Corporation

P.O. BOX 552 SANTA CLARA, CALIFORNIA 95052 TEL. (408) 988-5600 TWX: 910-338-0135

GENERAL DESCRIPTION

Synertek Systems has two KTM-2 models. The standard KTM-2 with its low video frequency (3.6MHz) can use an ordinary home TV as a video monitor. This keeps the user system costs low.

The KTM-2/80 has twice the displayable characters; however, it must be used with a video monitor since the 80 character lines have a higher frequency (7.2MHz). The KTM-2/80 is functionally identical in every other respect with the KTM-2. Throughout the remainder of this manual, KTM-2 will refer to both the KTM-2 and the KTM-2/80 unless otherwise noted.

The KTM-2 keyboard consists of 54 keys which generate 128 ASCII characters and 128 graphic characters. The ASCII characters include upper and lower case alpha, numeric, special and control. The graphic and alphanumeric characters can be displayed simultaneously. This is beneficial in business and industrial applications where annotated forms and graphs are desirable. With KTM-2's relative and absolute cursor addressing, graphs, game pieces, etc., can be placed and/or moved about on the screen with a minimal amount of software.

The KTM-2 has two serial communications ports: the main port used primarily with a computer for information transfer and the auxiliary port used primarily with a printer for hard copy. The serial ports are full duplex ports allowing information to be transmitted and received simultaneously. The serial format is comprised of a start bit, seven data bits, a parity bit (for detection of transmission errors), and one or two stop bits. The bit transmission rate is selectable from 110 up to 9600 baud (bits per second). The eight baud rates are selectable by three of the eight option switches.

Other switch selectable features are: even, odd or no parity; interlaced or non-interlaced screen; line truncate or line wrap around (to next line); and 60Hz or 50Hz frame rate.

KTM-2 SYSTEM START UP

Unpackaging

When unpackaging and carrying the KTM-2, care should be taken to avoid damage from static electricity discharge, such as walking across nylon carpets while in contact with circuit components. Keep the KTM-2 in the anti-static bag provided when not in use.

Included with the KTM-2 are three connectors: a power (9 pin) connector, a serial communication (25 pin) connector, and a video (coax jack) connector. Verify that the connectors are correct by mating them with their counterparts checking for a snug fit. Visually inspect for integrated circuits (IC's) and key caps that may have worked loose from their socket during shipping. Press in any loose components and the KTM-2 is now ready for operation.

Applying Power to the KTM-2

The KTM-2 power requirement is +5VDC $\pm 5\%$ at 1.1 amps for the KTM-2 and 1.3 amps for the KTM-2/80 typically. When connecting power to the KTM-2, be extremely careful not to reverse the power and ground leads, which may damage the integrated circuits. This is critical when first soldering the wires to the power connector. Once the wires are soldered correctly, the mechanical polarization of the power connector will prevent inadvertent reversal of power and ground.

When wiring the power leads, be sure to use the pin numbering shown in Figure 1 and not the numbering on the connector. The connector numbering may not be in agreement. Any of the +5V and ground pins listed may be used. NOTE: Only +5V and ground are needed for KTM-2 operation.

When power is applied and no other keys have been depressed since application of power, the alpha light (the LED next to the "ALPHA" key) will toggle on or off with each depression of the "ALPHA" key. If this does not happen, remove power and repeat the above procedure.

Connecting a Video Monitor to the KTM-2

There are two video signal levels available on the KTM-2. The video signal is ground to 1.0V with jumper J6 in place (see Figure 1) and ground to 2.4V with jumper J6 removed. The video signal consists of three voltage levels, sync (ground), black (also blanking), and white. Figure 2 shows this in more detail. When purchasing a video monitor be sure that one of the above input signals is adequate for proper operation.

Figure 1. KTM-2 Connector/Switch Assignments and Definitions

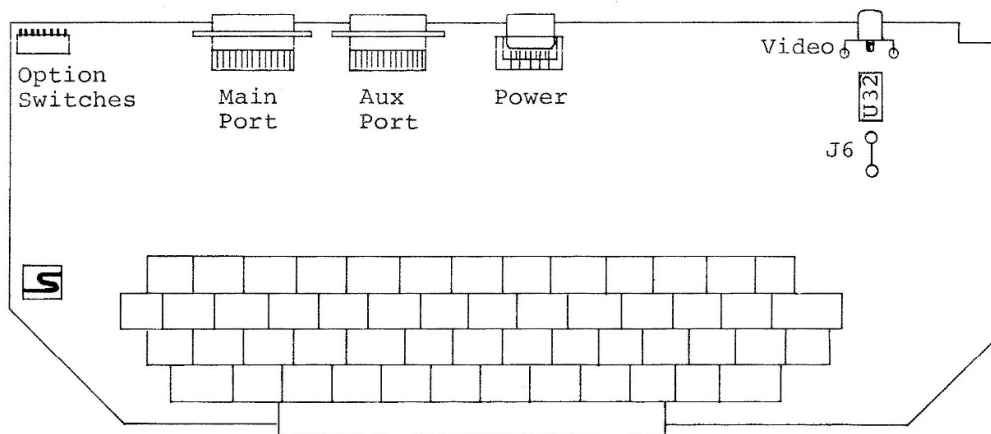
Power

pin 1 thru 5 on top

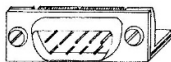

pin 6 thru 9 on bottom

Pin 1.	-12V (opt)
2.	+5V
3.	+5V
4.	+5V
5.	+12V (opt)
6.	GND
7.	GND
8.	GND
9.	GND

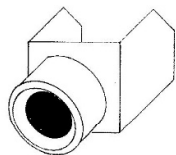
Video

Center conductor -- Video
 Outside conductor -- GND

Main and Aux Port

pin 13 thru 1 on top

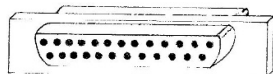

pin 25 thru 14 on bottom

Pin 1.	GND	14.	
2.	Tx	15.	
3.	Rx	16.	
4.	RTS	17.	
5.	CTS	18.	
6.	DSR	19.	
7.	GND	20.	DTR
8.		21.	
9.	Rx*	22.	Bell
10.		23.	DC
11.		24.	
12.	Tx*	25.	
13.			

* on Main Port only--these two signals are not buffered.

Figure 2. Typical Composite Video Signal

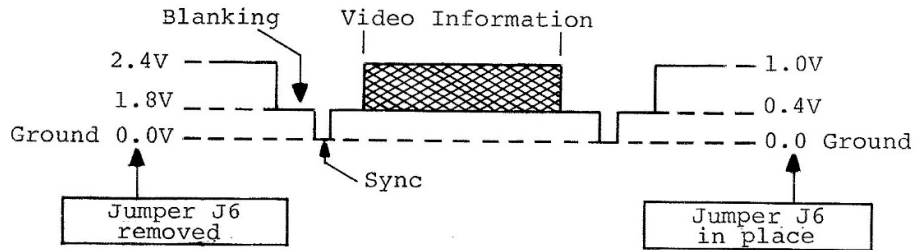

WARNING: Never connect the KTM-2 to the inside of a modified TV that is not electrically isolated from 110 VAC wall power by means of a transformer. Some inexpensive TV's are not isolated, and the chassis are hot (at a large electrical potential above ground). This will not only damage the KTM-2; the user may receive electrical shocks. For the above reasons, the KTM-2's video signal should be applied directly into a video monitor.

When connecting the video monitor, follow the manufacturer's directions. The KTM-2 video signal is on the center conductor of the coax connector. The ground is the outside shield.

The video monitor can be connected with the video jack provided. Before applying power, place all eight option switches (the eight switch package on the upper left corner of the board) in the ON position. If line power is 50Hz, as in Europe, place switch number 8 (the switch closest to the corner of the board) in the OFF position. Apply power to the KTM-2. There should now be a blinking cursor at the top left side of the video screen. Some adjustment of the monitor may be necessary (brightness, contrast, horizontal hold, etc.). When the video monitor has been properly adjusted, it is suggested that KTM-2 be placed in a local mode (explained below) so the operator can become familiar with the many features of the KTM-2 before connecting it to a computer.

Operating the KTM-2 in Local Mode

To operate the KTM-2 in local mode (independently, without connection to a computer), two connections must be made at the main serial port. One connection is the Transmit line (Tx, pin 2) to the Receive line (Rx, pin 3). The KTM-2 only displays the characters received on the Rx line. When a key is pressed, that character is transmitted (assuming $\overline{\text{CTS}}$ is asserted, explained below) on the Tx line. With the Tx and Rx lines connected, the character is received and displayed on the screen.

The other connection for local mode is to assert the Clear To Send line ($\overline{\text{CTS}}$, pin 5) by applying greater than +3 volts and less than +25 volts. This line informs the KTM-2 that the computer is ready to receive information. The KTM-2 will wait until this line is asserted before transmitting. The cursor will stop blinking during this wait period. Since the Request To Send line ($\overline{\text{RTS}}$, pin 4) is always at +5 volts, connecting it to the $\overline{\text{CTS}}$ line will make the KTM-2 ready for local mode operation.

In summary, connect Tx (pin 2) with Rx (pin 3) and connect $\overline{\text{CTS}}$ (pin 5) to $\overline{\text{RTS}}$ (pin 4) at the main port only. Be sure to wire according to the numbers shown in Figure 1 and not to the pin numbers on the connector. The numbering may not agree. With the two interconnections made on the main port connector, the KTM-2 is now ready to display characters. The following sections will aid the user in accessing the KTM-2 features.

KTM-2 FEATURES

When using the KTM-2 for the first time, the user should demonstrate the following features with the KTM-2 in the local mode (explained in the previous section). All examples assume the KTM-2 is in local mode.

Keyboard

The KTM-2 keyboard consists of 54 keys with gold-plated quadfurcated contacts for high reliability and long life. The keyboard scan incorporates two-key rollover. In addition, any key with the exception of SHIFT, CTRL, and ALPHA when held down for more than one half second, will automatically repeat. When a key other than SHIFT, CTRL, or ALPHA is depressed, the KTM-2 transmits the ASCII code corresponding to that key at the baud rate preselected at the option switches.

NOTE: Before each character transmission, the KTM-2 checks that CTS on the main port is asserted. If $\overline{\text{CTS}}$ (Main) is not asserted, KTM-2 will wait for it to be so. This waiting is evidenced by the fact that the cursor ceases blinking. When $\overline{\text{CTS}}$ (Main) is reasserted, the character will be transmitted and the cursor will resume blinking.

The special keys SHIFT, CTRL, and ALPHA modify the operation of the other keys. When SHIFT is held down simultaneously with another key, the character transmitted will be the uppercase for an alphabetic key and the upper key legend for all other keys.

When the CTRL key is held down simultaneously with another key, which may be shifted, the KTM-2 modifies the transmitted ASCII code into a control character. (See Table 1.) For example, from Table 1, LINE FEED, CTRL J, CTRL j, or CTRL * will move the cursor down, CTRL I will move the cursor right once space, etc. There are many key combinations that will transmit the same code.

When the ALPHA key is depressed, the ALPHA LED immediately right of the key is lighted. If the key is depressed again, the LED will go off. With each depression of the ALPHA key, the ALPHA LED will change state. While the ALPHA LED is lighted, all alphabetic keys and the DELETE key are automatically shifted to upper case. The non-alphabetic keys are not affected. This type of operation is very useful when communicating with a computer which expects to receive only upper case letters.

Another special key is TAB/BREAK. When TAB is depressed while SHIFT is held down a break operation is performed. The Tx line is held in the SPACING state (>+3 volts) for 450 ms, regardless of baud rate.

Table 1. ASCII Control Code Summary

<u>KEYS DEPRESSED</u>	<u>ASCII CONTROL CODE (Hexadecimal)</u>	<u>ACTION TAKE BY KTM-2</u>
CTRL G CTRL g CTRL '	07	Bell output
CTRL H CTRL h CTRL (08	Cursor back one space (backspace)
CTRL I CTRL i CTRL)	09	Cursor right one space (horizontal tab)
LINE FEED CTRL J CTRL j CTRL *	0A	Cursor down one space (line feed)
CTRL K CTRL k CTRL +	0B	Cursor up one space (vertical tab)
CTRL L CTRL l (alpha) CTRL ,	0C	Clear display and move cursor home (upper left) (form feed)
RETURN CTRL M CTRL m CTRL -	0D	Cursor to beginning of the same character line (carriage return)
CTRL S CTRL s CTRL 3	13	Set DC low
CTRL T CTRL t CTRL 4	14	Set DC high
ESC CTRL ; CTRL [1B	Begin ESCAPE sequence (see ESCAPE SEQUENCE)
CTRL SPACE CTRL @ CTRL SHIFT, RETURN	--	Reset KTM-2, clear screen and read option switches
CTRL ALPHA	--	Special--no output is sent over Tx; local clear screen
All Others		Ignored

Any of the following combinations of keys, depressed simultaneously will cause the KTM-2 to reset, clear the screen, and read the option switches.

CONTROL, SHIFT, @
 CONTROL, SHIFT, RETURN
 CONTROL, SPACE BAR
 CONTROL, ALPHA (local screen clear; no output is sent over Tx line)

Display Operation

The KTM-2 is a full-duplex terminal module. Serial data reception and transmission are asynchronous and may occur simultaneously. Transmission from the KTM-2 does not affect the video display. In normal operation, data transmitted from the terminal is echoed (re-transmitted) by the computer, and received by the terminal. The received data is displayed by the terminal.

With the KTM-2 operating in local mode, all data transmitted from the KTM-2 will also be received by it, and displayed on the screen.

As each displayable character is received, its character image appears in the location occupied by the cursor and the cursor moves to the next location.

Note: If the cursor stops blinking or disappears, CTS (Main) is not asserted. The computer is not ready to receive from the KTM-2 or there is a fault in the wiring.

ASCII control codes received do not cause characters to appear on the screen. However, many of them do affect the KTM-2 in other ways as summarized in Table 1.

Additionally, the DELETE (or RUBOUT) code (ASCII 7F) is ignored.

When the cursor is at the beginning of a line, a backspace will cause it to appear at the end of the previous line. When data is received past the end of a line, the cursor is automatically positioned at the beginning of the next line (i.e., a carriage return and line feed are performed).

When a line feed causes the cursor to be positioned below the last line (below line 23) of the display, a scroll operation is performed. In a scroll operation, every line on the display is shifted up one line. The line which was the first line is lost, and the line which was the second line becomes the first line. In this way the cursor remains on the display.

Special ASCII Codes

Several codes are not defined in the standard ASCII table. However, these are defined as special characters in the KTM-2 and are listed below. To transmit a special character, special key combinations have been established. The following examples, along with reference to Table A5, will make this more clear.

<u>KEY</u>	<u>LOWER CASE</u>	<u>UPPER CASE / CHAR. DISPLAY</u>	
ESC	1B (ESC)	7B	±
RETURN	0D (CR)	60	Σ
SPACE	20 (SP)	7C	π
LINE FEED	0A (LF)	7E	~
ALPHA	NONE	7D	†
DELETE	7F	5F	←

Example: Depressing LINE FEED will transmit a hex 0A, whereas, if the SHIFT key were simultaneously depressed a hex 7E is transmitted. Upon receiving a hex 0A, a line feed is performed, whereas a hex 7E would result in a "~" being displayed.

Depressing DELETE would transmit a hex 7F. If the SHIFT key were simultaneously depressed, a hex 5F is transmitted. The KTM-2 is not affected by receiving a hex 7F (see Table A5). However, a hex 5F will result in a "←" being displayed.

Escape Sequences

The KTM-2 is capable of responding to several instructions for which no ASCII control code is defined. Fortunately, the ASCII standard includes escape sequences for communicating such instructions.

The special control code ESC (ASCII 18) alerts the KTM-2 to interpret the next character as part of an escape sequence and not to display it.

All KTM-2 escape sequences, other than cursor addressing, consist solely of the escape code and one additional code. Cursor addressing will be discussed separately in the next section.

In the local mode the escape sequences listed in Table 2 may be initiated by depressing and releasing the ESC key, followed by a single additional key. Notice that the case of alphabetic codes is important, e.g., ESC R has the opposite effect of ESC r. Also, remember that lower case letters cannot be transmitted while the ALPHA LED is lighted.

Table 2. Escape Sequence Summary

<u>Sequence of Codes Received by KTM-2</u>	<u>Action Taken by KTM-2</u>
ESC E	FORM FEED: Display is cleared to spaces and cursor moved to first position of first line (the HOME position)
ESC H	HOME: Cursor is moved to HOME
ESC J	CLEAR EOS (End of Screen): Every position on the screen from the current position of the cursor to the last position of the last line, inclusive, is cleared to spaces. The position of the cursor does not change.
ESC K	CLEAR EOL (End of Line): Every position from the current position of the cursor to the end of the line occupied by cursor, inclusive, is cleared to spaces. The position of the cursor does not change.
ESC R	BEGIN REVERSE: All upper case letters and all graphics characters received subsequent to reception of the ESC R sequence will be displayed in reverse video.
ESC r	END REVERSE: All displayable characters received subsequent to reception of the ESC r sequence will be displayed in normal video.
ESC G	BEGIN GRAPHICS: Each displayable character received subsequent to reception of the ESC G sequence will cause one of the graphic characters (see Table A2) to be displayed.
ESC g	END GRAPHICS: Return to normal display mode
ESC L	AUX ON: Auxiliary serial port transmission is enabled on-line.
ESC l(alpha)	AUX OFF: Auxiliary serial port transmission is disabled.

Table 2. Continued

<u>Sequence of Codes Received by KTM-2</u>	<u>Action Taken by KTM-2</u>
ESC +	RELATIVE CURSOR ADDRESSING
ESC =	ABSOLUTE CURSOR ADDRESSING

Examples of ESC Sequences:

Data Received by KTM-2
(Starting from power-up
or reset)*

Displayed on Screen

abcABC

abcABC

ESC R abcDEF

abcDEF

ESC R ESC G ABCYZ

abc

ESC G ESC R ABC ESC r ABC ESC g ABC

abcABC

* Note: ESC is the escape key.

Cursor Addressing Examples:

<u>Sequence of Codes Received</u>	<u>Effect on Cursor</u>
ESC = SP SP	Cursor to HOME
ESC + SP SP	Position unchanged
ESC + * ,	Cursor down 10 and right 12
ESC + 7 G	Cursor down 23 and right 39 (or effectively, cursor up 1 and left 1 for a 24 x 40 character display)
ESC = , 4	Cursor to line 12, column 20

Graphics Display Mode

When the terminal is in graphics display mode (after reception of an ESC G sequence), all non-control characters received cause one of the special graphics characters to be displayed on the screen. Table A2 displays the reverse graphic character set. These characters are obtained by the sequence ESC G ESC R. ESC r subsequently will reverse the characters in Table A2.

INTERFACING THE KTM-2 WITH A COMPUTERSerial Communication Ports

The KTM-2 has two serial communications ports, the main and the auxiliary. All serial outputs from the KTM-2 are TTL voltage levels. The outputs, from a 74LS00 (U3), are not in agreement with EIA RS232C serial communication specification. However, the EIA RS232C requirements can be satisfied with some KTM-2 changes (see Appendix A). The TTL signal level outputs allow the KTM-2 to operate with a single +5V power source. Moreover, there are few electronic devices employing the EIA RS232C specification that will not also accept TTL voltage levels, hence the modifications for RS232C may not be required.

The KTM-2 serial inputs comply with the EIA RS232C specification and will accept the TTL voltage levels. The serial port electrical requirements are shown below:

<u>KTM-2</u>	<u>Asserted</u>	<u>Not Asserted</u>
Outputs	+2.4 to +5.0 Volts	0.0 to +0.4 volts
Inputs	+2.0 to +25 volts	-25 to +0.8 volts

Word Structure

The serial data ports (Main and Auxiliary) transfer data to and from the KTM-2 in standard asynchronous mode. The transmitted word consists of one start, seven data, one parity and one stop bits (2 stop bits if 110 baud is selected). If no parity is selected, (see section on Option Switches), the parity bit is held in the mark condition. When receiving a serial word, the KTM-2 expects one start, seven data, one parity (ignored) and one or more stop bits. More than one stop bit is treated as idle marking time. For both transmit and receive, a space is a high TTL level with mark being a low TTL level. Also, the least significant data bit is the first data bit sent and received.

Figure 3. Word Structure

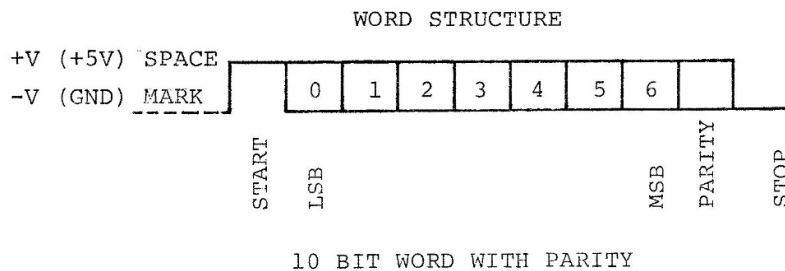

Communications Protocol

The KTM-2 operates in full-duplex mode. Characters are transmitted as they are typed but are displayed only as they are received. Display of characters typed is usually accomplished by having the computer or the modem echo back to the KTM-2. Characters may be received and transmitted simultaneously.

In addition to the signal ground, transmitted data, and received data lines, the RS232C standard specifies several handshake, or control lines. The KTM-2 deals actively with only two of these, CTS and DTR.

Before transmitting any character, the KTM-2 checks that CTS (Main) is asserted (>+3V). If it is not asserted, the transmission will not occur until CTS is asserted.

During clear operations, the KTM-2 is not ready to receive data. The KTM-2 communicates this not-ready status to the computer by lowering the DTR (Main) line. KTM-2 maintains RTS (Main) in the asserted condition (>+3V) at all times.

If the computer does not generate the CTS signal, CTS operation can be circumvented by wiring KTM-2's RTS directly to CTS. If this is done, allow approximately 10 milliseconds for any clear screen operations before transmitting the next character or that character will be ignored. The Main Port pin assignments are summarized in Table A3.

AUX (Auxiliary RS232C) Port

The most common use of the AUX port is to generate a hard copy listing of a terminal session. The AUX port Tx is enabled upon reception of an ESC L and disabled upon reception of ESC l (lower case L). The AUX port always operates at the baud rate selected for the Main port.

The RS232C convention defines the Tx as data transmitted from the terminal (peripheral) to the computer and defines the Rx line as data transmitted from the computer to the terminal (peripheral). Since the AUX port is for connecting a printer or peripheral, this port is designed to make the KTM-2 look as if it were the computer. Therefore, the Aux Tx is an input to the KTM-2 and the Aux Rx is an output. This is opposite that on the Main port.

While the Aux port is enabled, all data transmitted To or From the KTM-2 is also transmitted to the Aux port (see Figure A4). Data received by the KTM-2 From the Aux port is logically OR'ed with data received from the Main port at all times. For this reason the Main Rx and Aux Tx lines should not be active simultaneously.

The KTM-2 transmits data to the Aux device on the Rx(Aux) line, and receives data from the Aux device on the Tx(Aux) line. CTS (Aux) informs the Aux device of the KTM-2's ready status. It is identical to \overline{DTR} (Main). The \overline{DTR} (Aux) line is not examined by KTM-2. Table A4 is an Aux port summary.

Switch-Selectable Options

TRUNCATE: In the no-truncate mode of operation, if a line of received data exceeds the character line length, the KTM-2 automatically advances the cursor to the beginning of the next line. If this is not desired, select the truncate mode. In this mode, all lines are truncated at the end of the line. No further data is displayed until a carriage return or other cursor positioning command is received (data is lost).

INTERLACE: Interlace is the ability to superimpose two pictures on odd and even lines to create an apparent doubling of the number of lines, increasing display resolution. Interlace should be used with screens having long persistence phosphors (P-39 or P-40) because the display screen may seem to flicker with other phosphors.

PARITY: If parity is selected, then the parity of transmitted data will be selected by the Even/Odd Parity select switch. If no parity is selected, the parity bit is maintained in the marking state, and may be interpreted as an extra stop bit or idle time by a computer which expects 7 bits of data.

EVEN/ODD PARITY: This switch selects even or odd parity, used by some equipment to detect data transmission errors.

BAUD RATE: These switches select one of eight standard data transfer rates. Additionally, if 110 baud is selected, the transmitted data word structure will include two stop bits. For all other baud rates, the word structure will include only one stop bit.

60/50Hz FRAME RATE: This switch selects the television frame rate. This is identical to the frequency of the AC power. Hence, in the USA the switch is set for 60Hz and in Europe the switch is set for 50Hz operation.

Option Switches

These switches are examined only during power-up and keyboard reset. Altering the switch positions will have no effect upon terminal operation until the next power-up or reset. NOTE: Look at switches to determine which position, up or down, is the "on" and "off" position.

Figure 4. Option Switches

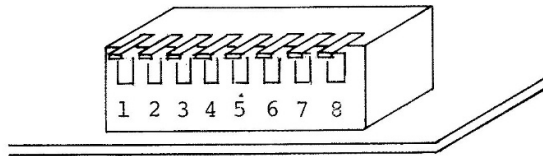

	<u>ON</u>	<u>OFF</u>
1	No Truncate	Truncate
2	No Interlace	Interlace
3	No Parity	Parity
4	Odd Parity	Even Parity
5	See Below	
6	See Below	
7	See Below	
8	60Hz Frame Rate	50Hz Frame Rate

5	6	7	Baud Rate
On	On	On	110
On	On	Off	300
On	Off	On	600
On	Off	Off	1200
Off	On	On	2400
Off	On	Off	4800
Off	Off	On	7200
Off	Off	Off	9600

APPENDICES

Appendix A. MODIFICATION FOR EIA RS232C VOLTAGE LEVELS

To prepare the KTM-2 for EIA RS232C voltage levels, replace U3, 74LS00, with a 1488 RS232 driver and change jumpers J7 and J8 per Figure A1. With these changes made, +12 volts must be supplied to the power connector, pin 5, and -12 volts must be supplied to pin 1. Refer to the note below.

The +12 volt pin has a voltage range of +9 to +25 volts and the -12 volt pin has a voltage range of -9 to -25 volts. The voltage applied may be anywhere between these values to comply with RS232C specifications. The following is a list of part numbers and manufacturers of the 1488 IC.

<u>Manufacturer</u>	<u>Part Number</u>
AMD	1488
Exar	XRL488
Fairchild	μ A1488
Harris	HD1488
ITT	ITT1488
Motorola	MC1488
National	DS1488
Raytheon	RC1488
Signetics	MC1488
Silicon G	SG1488
TI	MC1488

NOTE: When wiring $\pm 12V$, be sure to use the pin numbering shown in Figure 1 page 3 and not the numbering on the connector. The connector numbering may not be in agreement with the connector shown in Figure 1.

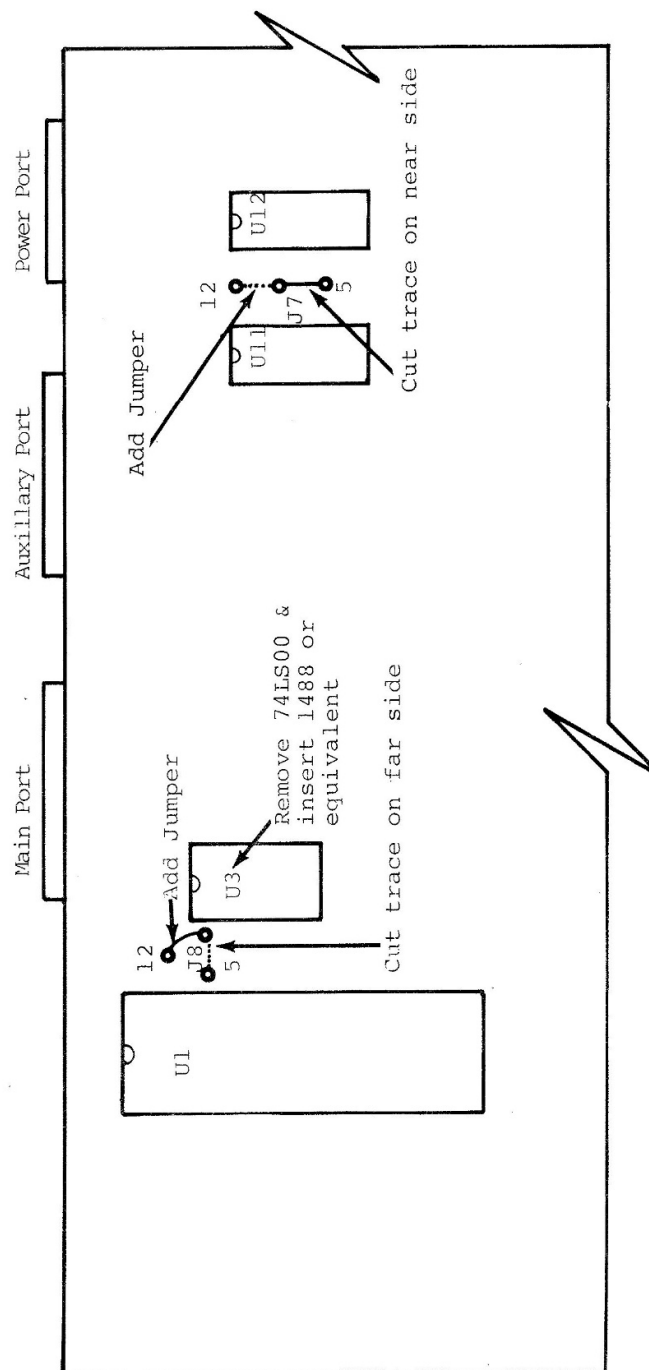
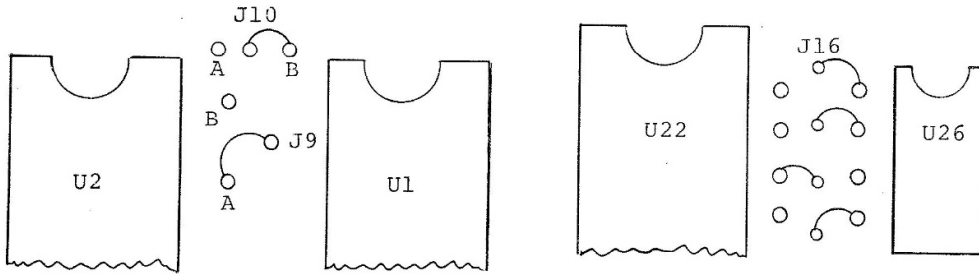

Figure A1. Modifications Necessary for Full EIA Operation

Appendix B. ADDING BLANK SCAN LINES BETWEEN CHARACTER ROWS

The KTM-2's character row consists of 8 scan lines, consequently, the rows are very close. This was done primarily for graphics to allow the characters to connect in the vertical direction. If more spacing is required between character rows, one or two blanked line(s) can be added. This is accomplished by making the jumper changes shown in Figures A2 and A3.

Figure A2. Scan Line Jumper Configurations



This is the configuration of the KTM-2 initially.

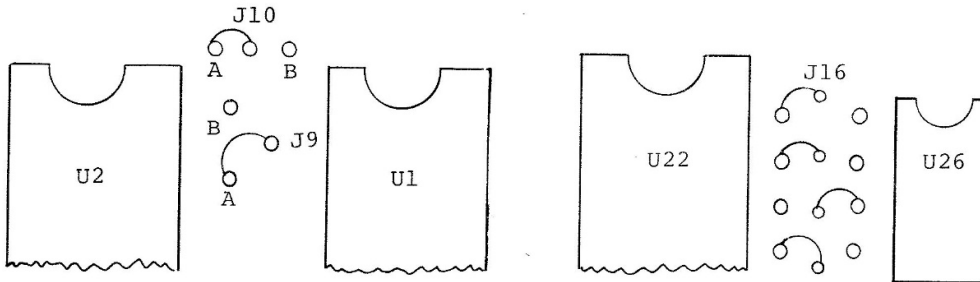

This is the configuration for one scan line added to the top.

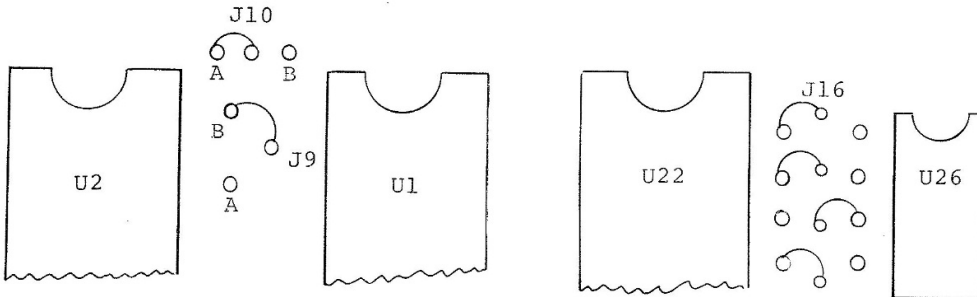

This is the configuration for two scan lines added (one on top; one on bottom)

Figure A3. Scan Line Jumper Locations

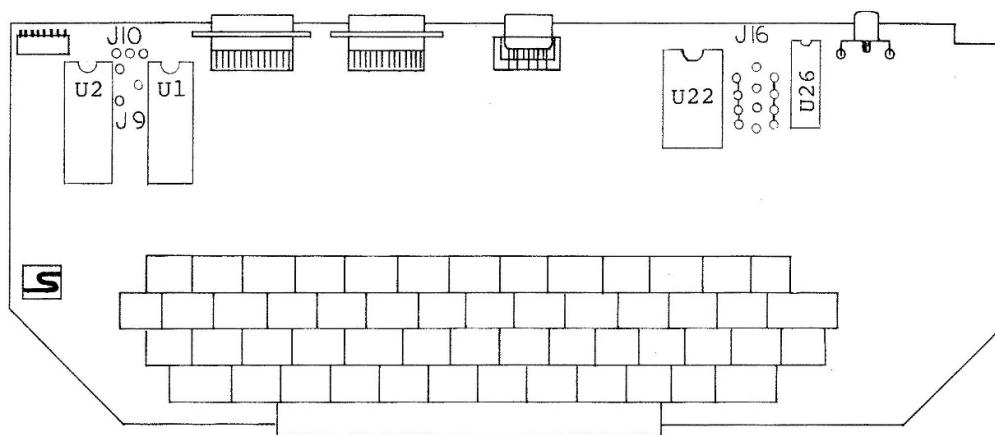

Appendix C. PROGRAMMING THE KTM-2 FROM SYNERTEK BASIC (BAS-1)

Users of the KTM-2 who also have a SYM-1 with BAS-1 installed, may find the following statements useful:

<u>Function</u>	<u>Statement</u>
Clear Screen	PRINT CHR\$(27)+"E";
Begin Graphics	PRINT CHR\$(27)+"G";
End Graphics	PRINT CHR\$(27)+CHR\$(103);
Begin Reverse	PRINT CHR\$(27)+"R";
End Reverse	PRINT CHR\$(27)+CHR\$(114);
Relative Addressing	PRINT CHR\$(27)+" "+CHR\$(V+32)+CHR\$(H+32);
Absolute Addressing	PRINT CHR\$(27)+"="+CHR\$(V+32)+CHR\$(H+32);

Any of the above statements may be either used in a BASIC program or executed directly in the Direct Command mode. Note that a minimum 18 millisecond delay is necessary after a Clear Screen statement before the KTM-2 will recognize more input. In the cursor addressing statements, V and H are the vertical and horizontal displacements for Relative Addressing or are the display locations for Absolute Addressing.

Graphics characters, for example a graphics plus sign, may be output after a Begin Graphics statement by:

```
PRINT CHR$(112)
```

where 112 is the decimal ASCII value for the letter "p." As with other BASIC statements, these statements may be grouped in For ... Next loops with variable arguments to generate complex graphics.

USERS NOTES

Figure A4. KTM-2 Serial Communication Schematic

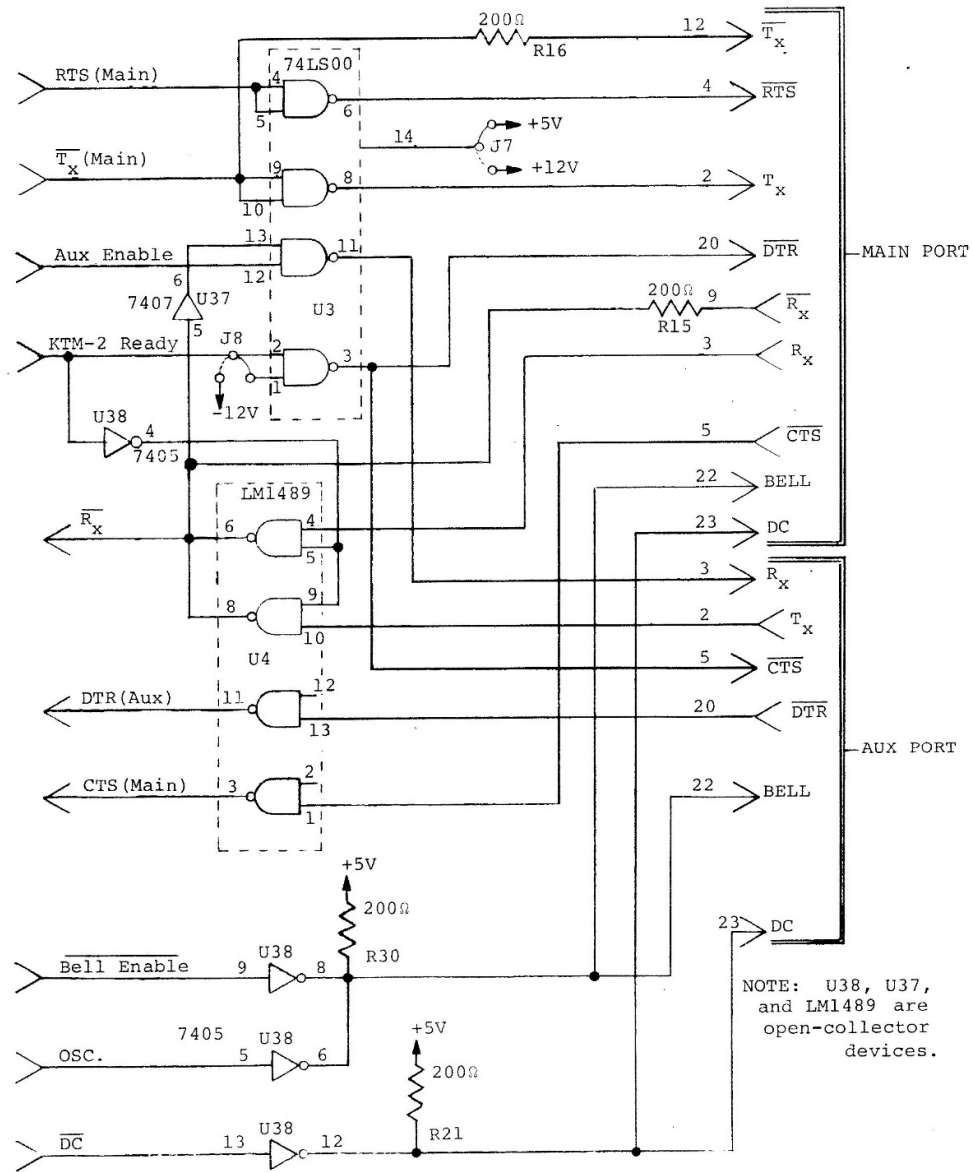

Figure A5. Video Output Schematic

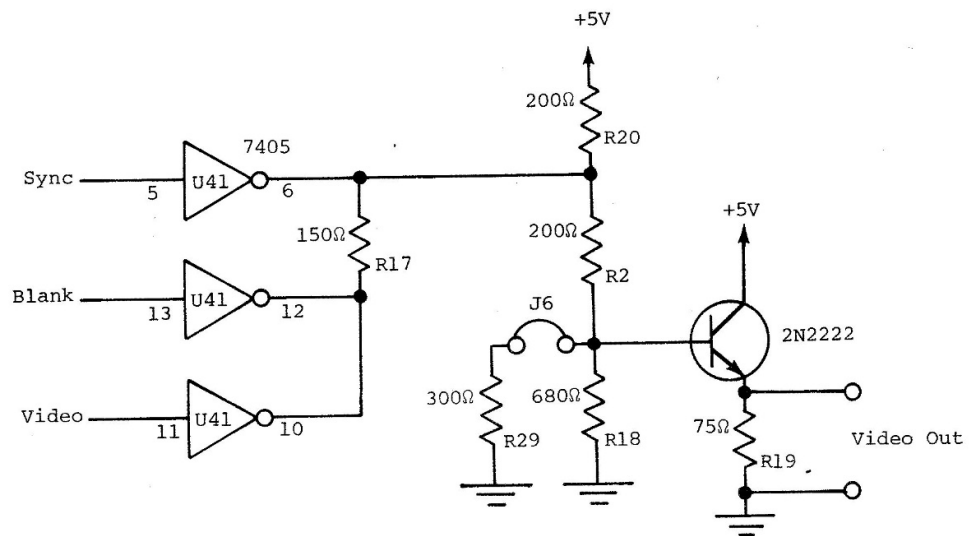

Figure A6. Component Layout

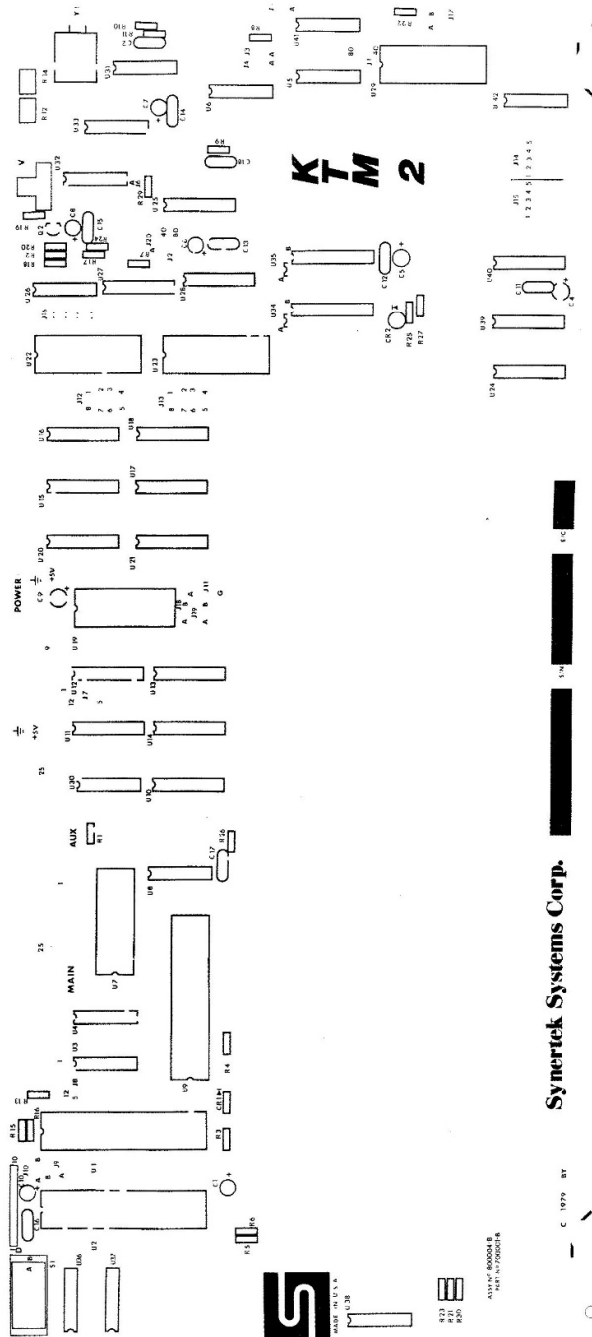

Table A1. Cursor Addressing Codes

ADDRESS OR DISPLACEMENT VALUE	ASCII	ADDRESS OR DISPLACEMENT VALUE	ASCII	ADDRESS OR DISPLACEMENT VALUE	ASCII
0	SPACE	27	;	54	V
1	!	28	<	55	W
2	,,	29	-	56	X
3	#	30	>	57	Y
4	\$	31	?	58	Z
5	%	32	@	59	[
6	&	33	A	60	\
7	,	34	B	61]
8	(35	C	62	^
9)	36	D	63	+
10	*	37	E	64	HEX 60
11	+	38	F	65	a
12	comma	39	G	66	b
13	-	40	H	67	c
14	.	41	I	68	d
15	/	42	J	69	e
16	0	43	K	70	f
17	1	44	L	71	g
18	2	45	M	72	h
19	3	46	N	73	i
20	4	47	O	74	j
21	5	48	P	75	k
22	6	49	Q	76	l
23	7	50	R	77	m
24	8	51	S	78	n
25	9	52	T	79	o
26	:	53	U		

The ASCII code HEX 60 may be achieved by depressing SHIFT and RETURN simultaneously.































































@ 40		P 50		SHIFT, CARRIAGE RETURN 60		p 70	
A 41		Q 51		a 61		q 71	
B 42		R 52		b 62		r 72	
C 43		S 53		c 63		s 73	
D 44		T 54		d 64		t 74	
E 45		U 55		e 65		u 75	
F 46		V 56		f 66		v 76	
G 47		W 57		g 67		w 77	
H 48		X 58		h 68		x 78	
I 49		Y 59		i 69		y 79	
J 4A		Z 5A		j 6A		z 7A	
K 4B		[5B		k 6B		SHIFT, ESCAPE 7B	
L 4C		\ 5C		l 6C		SHIFT, SPACE BAR 7C	
M 4D	] 5D		m 6D		SHIFT, ALPHA 7D	
N 4E		↑ 5E		n 6E		SHIFT, LINE FEED 7E	
O 4F		SHIFT, DELETE 5F		o 6F		DELETE 7F	

Table A2. Graphic Characters
(Obtained by the following sequence: ESC G)

Table A3. Main Port Pin Assignment

RS232C DB 25 CONN	NAME	I/O	FUNCTION
1	GND		Frame Ground (same as signal ground on pin 7)
2	Tx	O	Data Out (from KTM-2)
3	Rx	I	Data In (to KTM-2)
4	$\overline{\text{RTS}}$	O	Request to Send: Always at +5V
5	$\overline{\text{CTS}}$	I	Clear to Send: Must be a high TTL level for KTM-2 to send data. Note: If $\overline{\text{CTS}}$ is not asserted by the external device (computer), connect this pin to $\overline{\text{RTS}}$ for +5V. The KTM-2 will not transmit unless $\overline{\text{CTS}}$ is asserted. (The cursor will stop blinking.)
6	$\overline{\text{DSR}}$	I	Data Set Ready. No connection in KTM-2.
7	GND		Signal Ground.
12	$\overline{\text{Tx}}$	O	Inverted Transmit Line (TTL voltage level only)
9	$\overline{\text{Rx}}$	I	Inverted Receive Line (TTL voltage level only)
20	$\overline{\text{DTR}}$	O	Data Terminal Ready: A high level indicates KTM-2 is ready to accept data. $\overline{\text{DTR}}$ goes low (not ready) during form feed and clear screen operations.
22	BELL	O	Output for speaker.
23	DC	O	Device Control: This line is set low upon reception of an ASCII 13 hex, high upon reception of an ASCII 14 hex.

"I" is Input to KTM-2. "O" is Output from KTM-2.

Table A4. Aux Port Pin Assignments

RS232C DB 25 CONN	NAME	I/O	FUNCTION
1	GND		Frame Ground
2	Tx	I	Data In (to KTM-2)
3	Rx	O	Data Out (from KTM-2)
4	<u>RTS</u>	I	No connection in KTM-2
5	<u>CTS</u>	O	Clear to Send: Informs Aux device of KTM-2's ready status. All data Tx'd while <u>CTS</u> is low will be ignored.
6	<u>DSR</u>	O	Data Set Ready: Connected to +5V inside the KTM-2
7	GND		Signal Ground
20	<u>DTR</u>	I	Data Terminal Ready: Not used in KTM-2
22	BELL	O	Output for Speaker
23	DC	O	Device Control: Same as main port

"I" is Input to KTM-2. "O" is Output from KTM-2.

Table A5. KTM-2 ASCII Character Set

MSB \ LSB		CONTROL CHARACTERS		NORMAL DISPLAYED CHARACTERS							
		0	1	2	3	4	5	6	7		
0				SPACE	Ø	@	P	Σ	P		
1				!	1	A	Q	a	q		
2				"	2	B	R	b	r		
3			SET DC LOW	#	3	C	S	c	s		
4			SET DC HIGH	\$	4	D	T	d	t		
5				%	5	E	U	e	u		
6				&	6	F	V	f	v		
7		BELL		'	7	G	W	g	w		
8		BACK SPACE		(8	H	X	h	x		
9		CURSOR RIGHT)	9	I	Y	i	y		
A		LINE FEED		*	:	J	Z	j	3		
B		CURSOR UP	ESCAPE	+	;	K	[k	±		
C		FORM FEED		>	<	L	\	l	π		
D		CARRIAGE RETURN		-	=	M]	m	†		
E				•	>	N	↑	n	~		
F				/	?	O	←	o	NONE		

All unused control characters are ignored.
 MSB = most significant byte
 LSB = least significant byte

Table A7. KEYBOARD TERMINAL MODULE

MATERIALS LIST

Qty. per KTM 2/80	Qty. per KTM 2	Part Number	Description	Ref. Designation
1	1	SYP6502	CPU	U9
2	2	SYP6522	VIA	U1, U2
1	1	SYP6507	CPU, Video	U7
2		SYP2316B	ROM, Character	U22, U23
	1	SYP2316B	ROM, Character	U22
1	1	SYP2114-3	RAM	U15, U16, U17 U18
1	1	7408	Gate, AND	U30
1	1	7420	Gate, NAND	U32
1	1	74109	J- \bar{K} Flip-Flop	U25
5	5	74157	2-to-1 Multiplexer	U10, U11, U12 U13, U14
2	1	74166	8-Bit Shift Register	U27, U28
1	1	74LS00	Gate, NAND	U3
1	1	74S04	Gate, Inverter	U31
2	2	7493	Counter	U8, U33
2	1	AM8304	Port, Bi-directional	U34, U35
2	2	7405	Gate, Inverter	U38, U41
2	2	7407	Buffer	U36, U37
1	1	74197	Counter	U26
1	1	1489	Buffer	U4
3	3	1K Ω , $\frac{1}{4}$ W, $\pm 5\%$	Resistor	R5, R6, R13
1	1	10K Ω , $\frac{1}{4}$ W, $\pm 5\%$	Resistor	R3
1	1	150 Ω , $\frac{1}{4}$ W, $\pm 5\%$	Resistor	R17
10	10	200 Ω , $\frac{1}{4}$ W, $\pm 5\%$	Resistor	R2, R10, R11 R15, R16, R20 R21, R25, R26 R30

Qty. per KTM 2/80	Qty. per KTM 2	Part Number	Description	Ref. Designation
1	1	300 Ω , $\frac{1}{4}$ W, $\pm 5\%$	Resistor	R29
6	6	3.3K Ω , $\frac{1}{4}$ W, $\pm 5\%$	Resistor	R1, R4, R7, R9 R23, R24
1	1	680 Ω , $\frac{1}{4}$ W, $\pm 5\%$	Resistor	R18
1	1	75 Ω , $\frac{1}{4}$ W, $\pm 5\%$	Resistor	R19
1	1	30pf	Capacitor	C17
7	7	10 μ f, 25V	Capacitor	C1, C5, C6, C7 C8, C9, C10
6	6	.01 μ f, 50V	Capacitor	C2, C12, C13 C14, C15, C16
1	1	PN2222	Transistor	Q1
1	1	IN914	Diode	CR1
2	2	ITT/Cannon DBP25SAA	Connector, 25-Pin "MAIN"	
1	1	Connector Corp. 107E65-4	Connector, Audio "V"	
1	1	ITT/Cannon DEC-9PAA	Connector, 9-Pin "POWER"	
1	1		Keyboard	KB1
1	1	Alco CYS-8	Dip Switch, 8-Position	S1
1	1	Litronix RL 4850	L.E.D.	CR2
1	1		Crystal	Y1
1	1		PCB	

Figure A8. Local Mode Trouble Shooting Flowchart

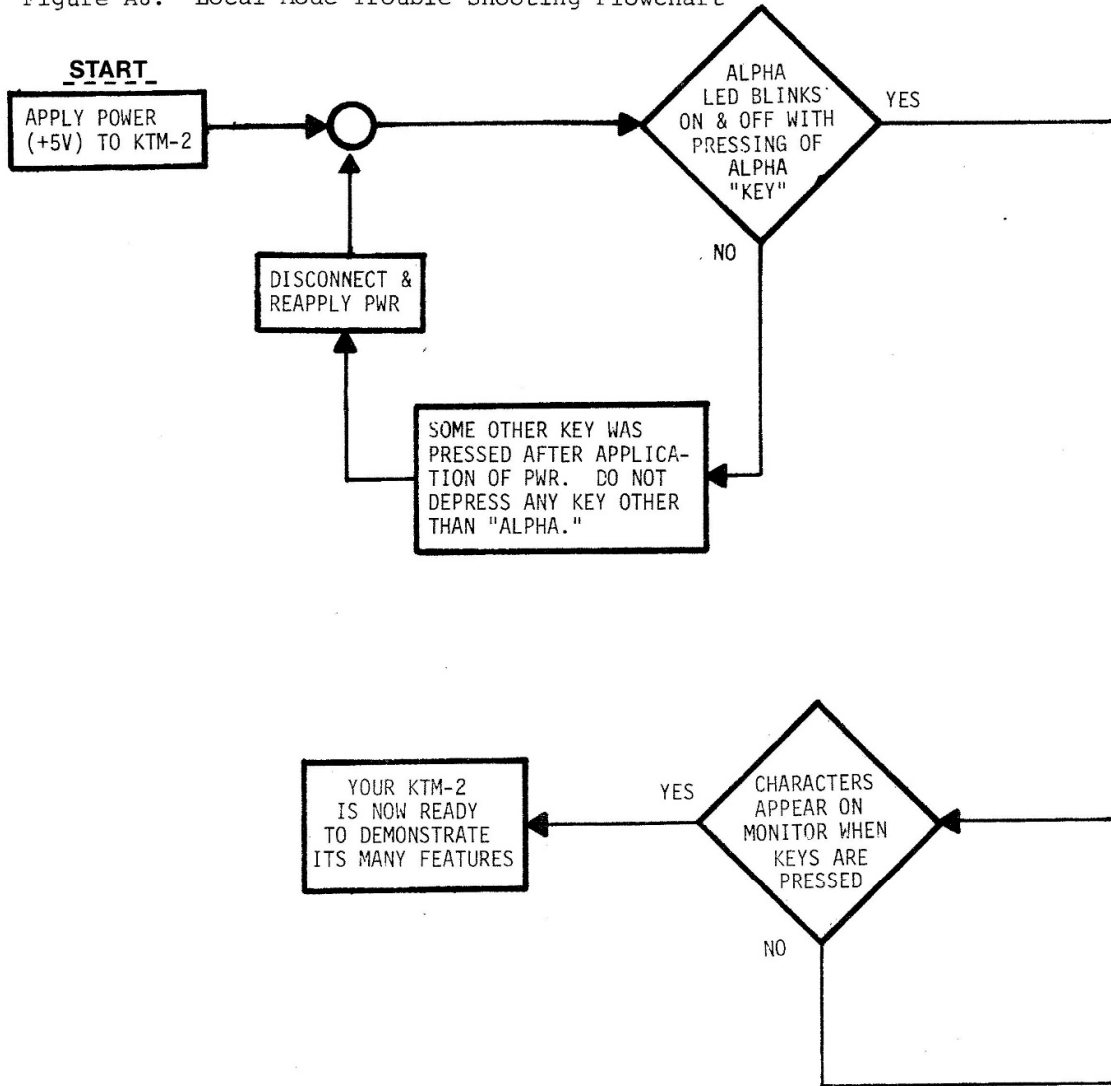

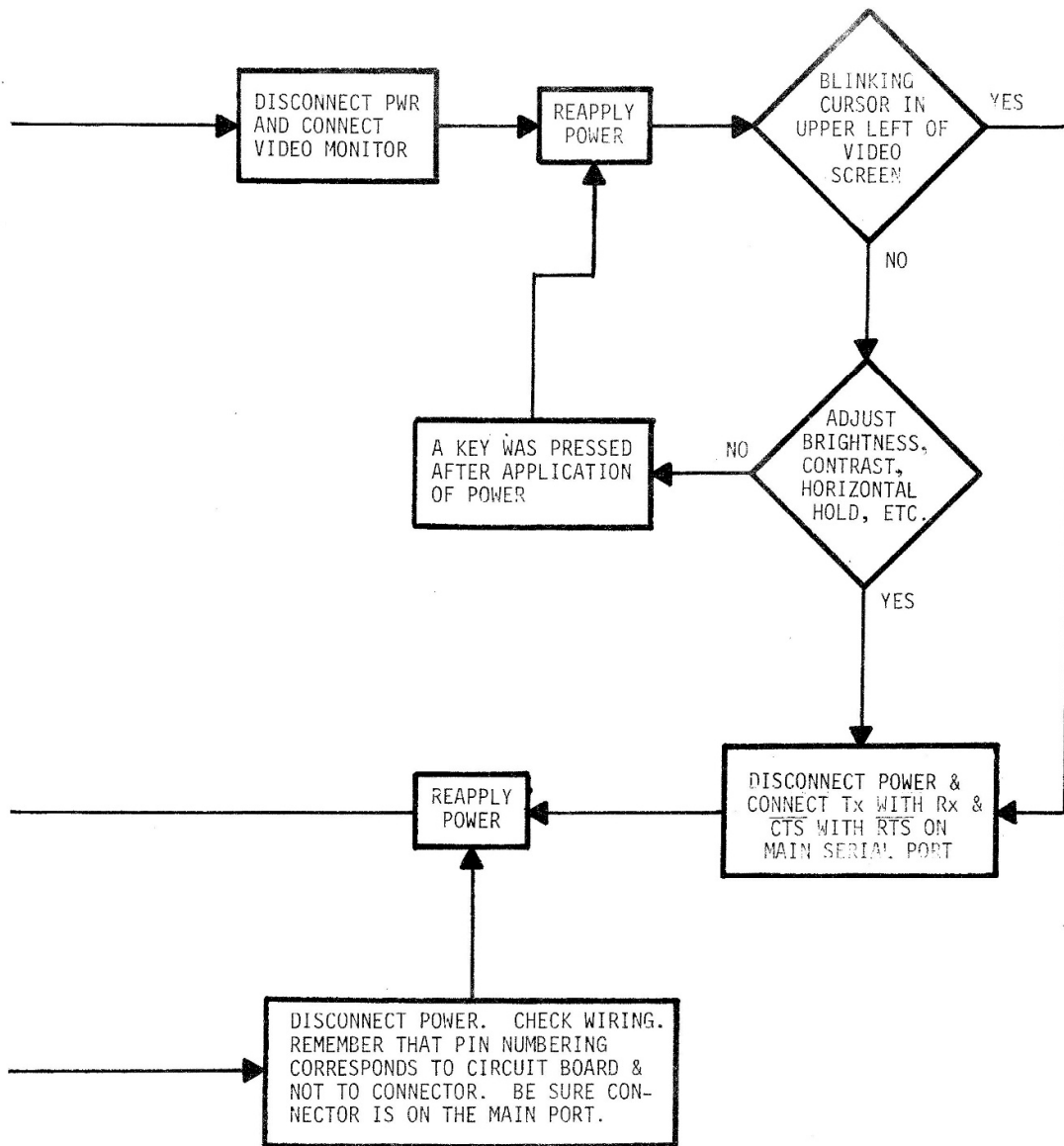



Synertek Systems Corporation
150 South Wolfe Road · Sunnyvale, CA 94086

Printed in U.S.A.